

8 7 6 5 4 3 2 1

D
C
B
A

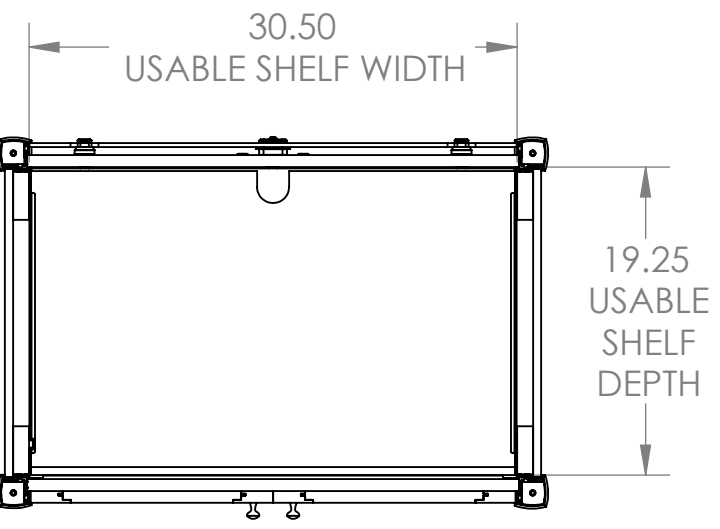

*TOP VIEW WITH
TOP PANEL REMOVED*

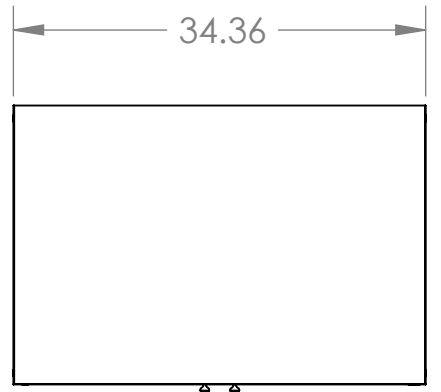

TOP SHELF CAPACITY
60LBS
MID SHELF CAPACITY
50LBS
BOTTOM SHELF CAPACITY
100LBS

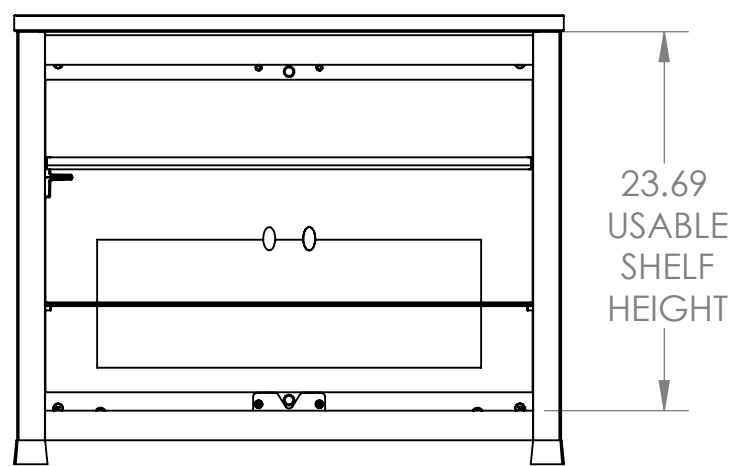

*FRONT VIEW WITH
DOOR ASSEMBLIES REMOVED*

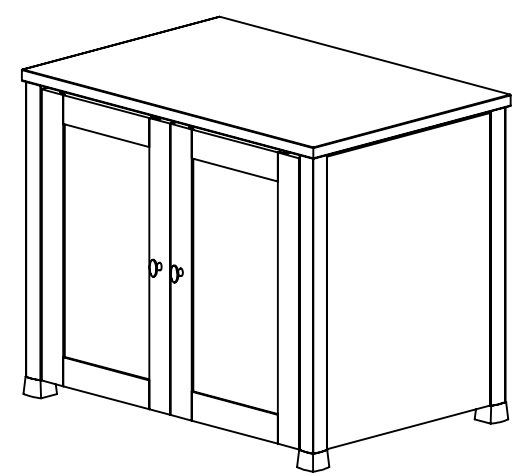
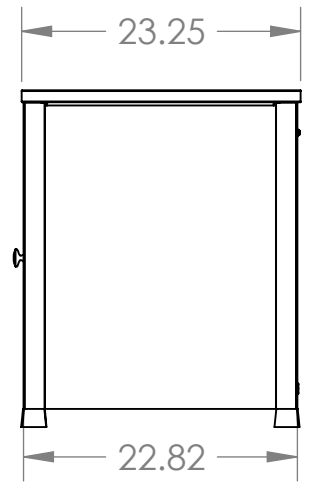
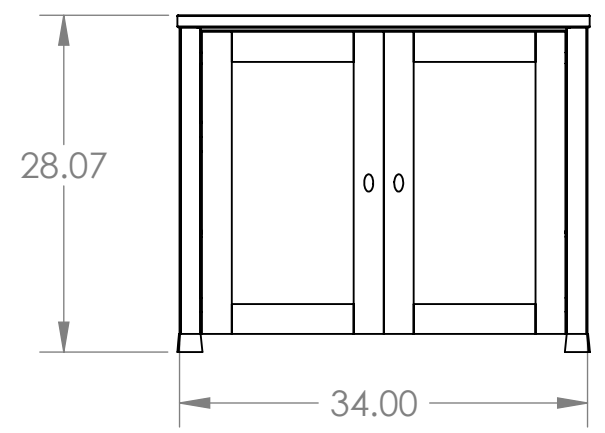

D
C
B
A

	NAME	DATE	SANUS SYSTEMS	
ENGINEER	JKV	12/17/2007	TITLE:	
DESIGNER		-	CFAV34	
APPROVED		-		
NOTES:			SIZE	DWG. NO.
			B	CFAV34
			REV	01
TEMPLATE REV.:	05	SCALE: 1:16	WEIGHT: 100.34	SHEET 1 OF 1

PROPRIETARY AND CONFIDENTIAL
THE INFORMATION CONTAINED IN THIS DRAWING IS THE SOLE PROPERTY OF SANUS SYSTEMS, A PRODUCT DIVISION OF MILESTONE AV TECHNOLOGIES. ANY REPRODUCTION IN PART OR AS A WHOLE WITHOUT THE WRITTEN PERMISSION OF SANUS SYSTEMS IS PROHIBITED.

8 7 6 5 4 3 2 1