

SANUS[®]

A brand of **Legrand**

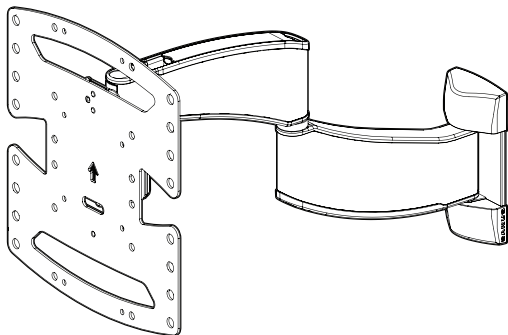

VDSF16

INSTRUCTION MANUAL

Texto en español, página 23

**GET IT
RIGHT
THE FIRST TIME**

**Follow this step-by-step
instruction manual to
speed up your installation.**

WE'RE HERE TO HELP



Want to watch a video that shows how easy this DIY project will be?



Watch it now at:
SANUS.com/3077



Get it right the first time. HeightFinder™ shows you where to drill.



Check it out at:
SANUS.com/1172



Ourlive, US-based install experts are standing by to help.



Call us at:
US: [+1 \(800\) 359-5520](tel:+18003595520)



Or, chat at:
SANUS.com/chatSP

Before you begin

Remove the stand from your TV — if attached.

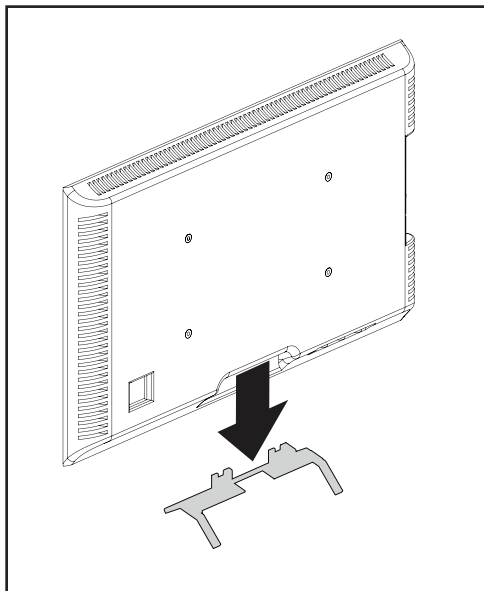

Install any accessories

you may have purchased — if they require the TV to be removed from the wall for assembly. The TV is removable for future accessory purchases.

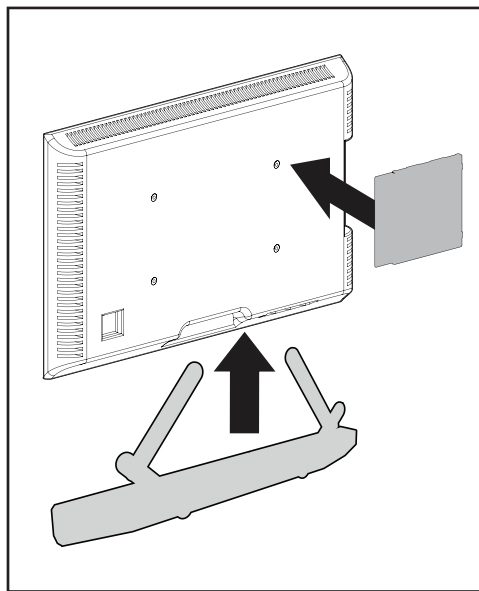

Protect the face of your TV when laying it down for installation.

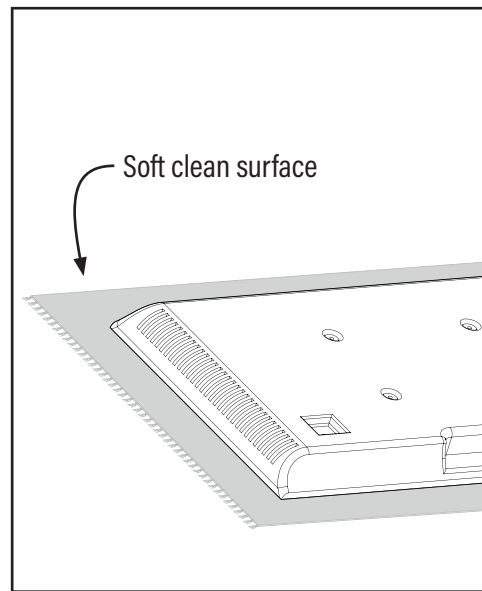

IMPORTANT SAFETY INSTRUCTIONS – PLEASE READ MANUAL PRIOR TO USE – SAVE THESE INSTRUCTIONS

Please read through these instructions completely to be sure you're comfortable with this easy install process.

Check your TV owner's manual to see if there are any special requirements for mounting your TV.

If you do not understand these instructions or have doubts about the safety of the installation, assembly or use of this product, contact Customer Service: +1 (800) 359-5520.

⚠ CAUTION: Avoid potential personal injuries and property damage!

- This product is designed **ONLY** to be installed into wood studs, solid concrete or concrete block.
— **DO NOT INSTALL INTO DRYWALL ALONE — DRYWALL ALONE WILL NOT HOLD THE WEIGHT OF YOUR TV.**
- This product is designed for **INDOOR USE ONLY**.
- The wall must be capable of supporting five times the weight of the TV and mount combined.
- Do not use this product for any purpose not explicitly specified by manufacturer.
- Manufacturer is not responsible for damage or injury caused by incorrect assembly or use.

TV Weight Limit
(including accessories)

DO NOT EXCEED



If your TV (including accessories) exceeds this weight, this mount is NOT compatible.

Visit SANUS.com or call customer service to find a compatible mount.

Wall Construction

ONLY install on these acceptable wall types.

? Unsure

Call Customer Service
+1 (800) 359-5520

⚠ CAUTION:

DO NOT install
in drywall alone

Drywall alone
will NOT hold
the weight of
your TV.



wood studs

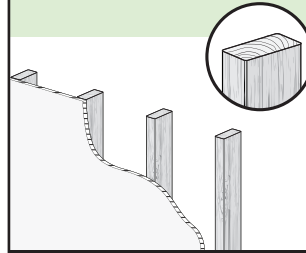

ACCEPTABLE

Solid concrete or
concrete block

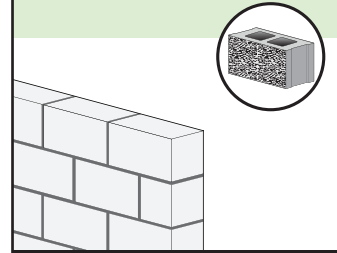

ACCEPTABLE

Tools Needed



Tape Measure



Pencil

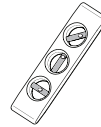

Level



Tape



Screwdriver



Electric Drill



7/16 in.
(11 mm)
Socket Wrench



Wood Stud Install

Stud Finder



Awl



1/8 in.
(3 mm)
Wood
Drill Bit



Concrete Install

3/8 in.
(10 mm)
Concrete
Drill Bit



Hammer

STEP 1

Attach TV Bracket to TV

WARNING: This product contains small items that could be a choking hazard if swallowed. Before starting assembly, verify all parts are included and undamaged. If any parts are missing or damaged, do not return the damaged item to your dealer; contact Customer Service. Never use damaged parts!

NOTE: Not all hardware included will be used.

STEP 1 Parts and Hardware

01 TV Screws
(qty. 4 each) [Only one size fits your TV]

M4



M4 x 12mm

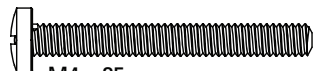

M4 x 35mm

M6

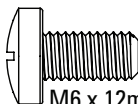

M6 x 12mm

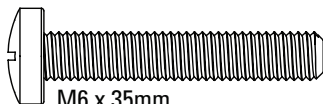

M6 x 35mm

M8

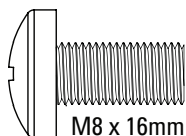

M8 x 16mm

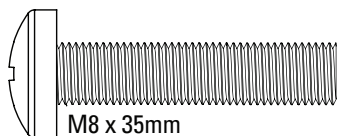

M8 x 35mm

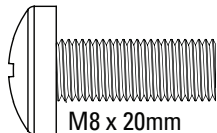

M8 x 20mm

Washers
(qty. 4 each)

02

M4/M5

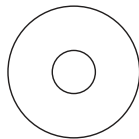

M6/M8

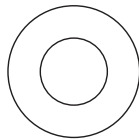

Spacers [If necessary]
(qty. 4 each)

03

M4/M6/M8

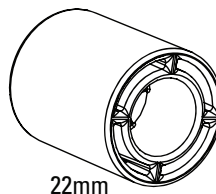

22mm

TV Bracket

04 (qty. 1)

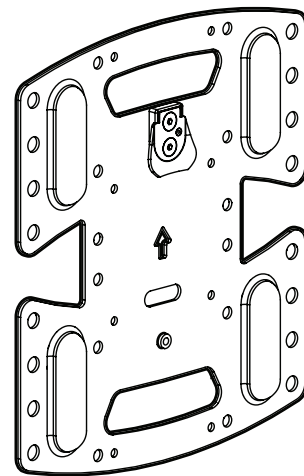

1.1 Select TV Screw Diameter

Only one screw size fits your TV.

M4

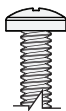

M6

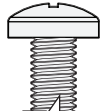

M8

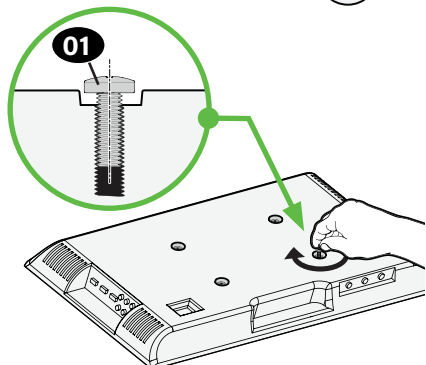
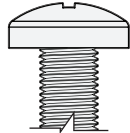

 If your TV included inset spacers or wall mount adapters, see Troubleshooting on PAGE 21.

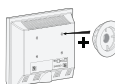

1.2 Select TV Screw Length and Spacers

A NO SPACER

Flat Back TV

[TV brackets lay flat on your TV]

Use **short** TV screws **01**.
Spacers **03** not needed.

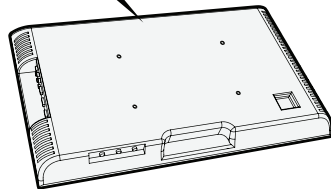
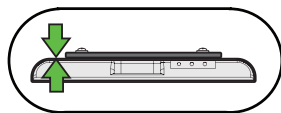

B SPACER NEEDED

Flat Back TV with Extra Space Needed

[for deep inset holes or cable interference]

Use **long** TV screws **01** and spacers **03** to create extra space between the TV and TV bracket.

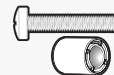

Inset Holes

Cables

Rounded Back

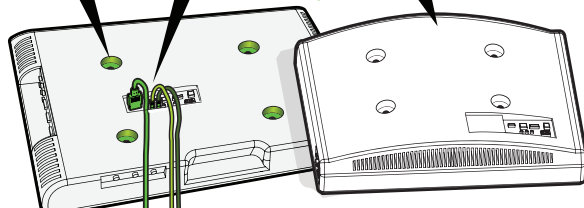
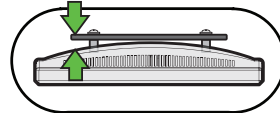
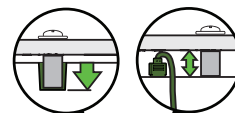

⚠ CAUTION: Verify adequate thread engagement with your screw **01**, washer **02**, spacer **03** combination AND TV bracket **04**.

- Too short will not hold your TV.
- Too long will damage your TV.



Too Short

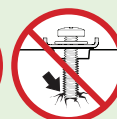

Too Long

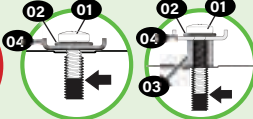

Correct

1.3 Attach TV Bracket to Your TV

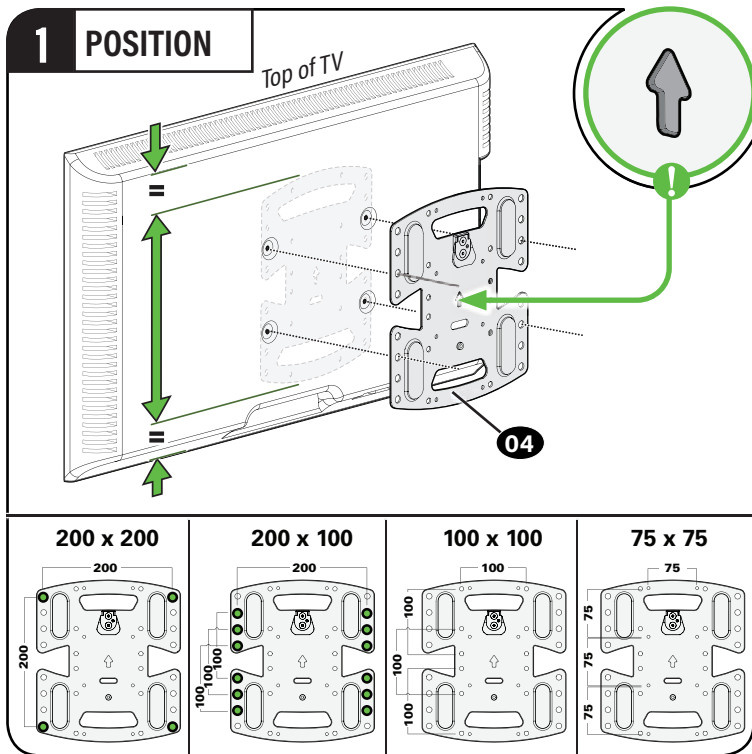

Center TV bracket **04** over your TV hole pattern as shown.
Various hole positions included for non-centered TV hole patterns.

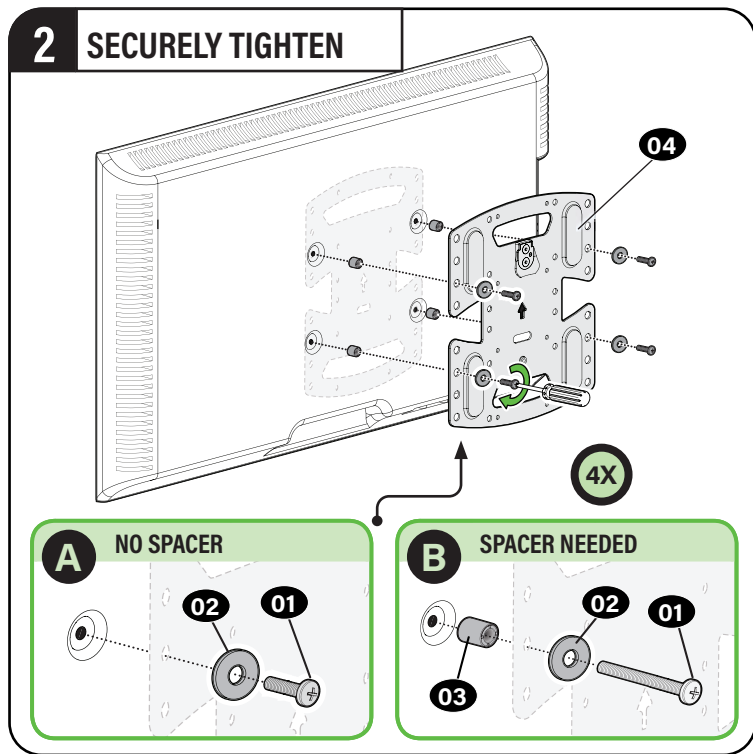

STEP 2

Attach Wall Plate to Wall

WARNING: This product contains small items that could be a choking hazard if swallowed. Before starting assembly, verify all parts are included and undamaged. If any parts are missing or damaged, do not return the damaged item to your dealer; contact Customer Service. Never use damaged parts!

NOTE: Not all hardware included will be used.

Parts and Hardware for STEP 2

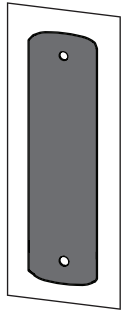

Drill Template
05 x1

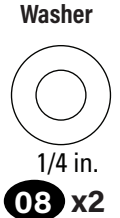
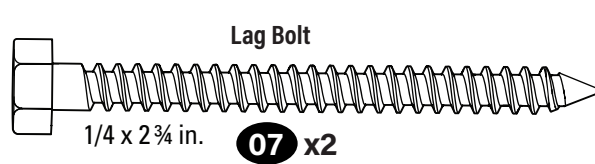
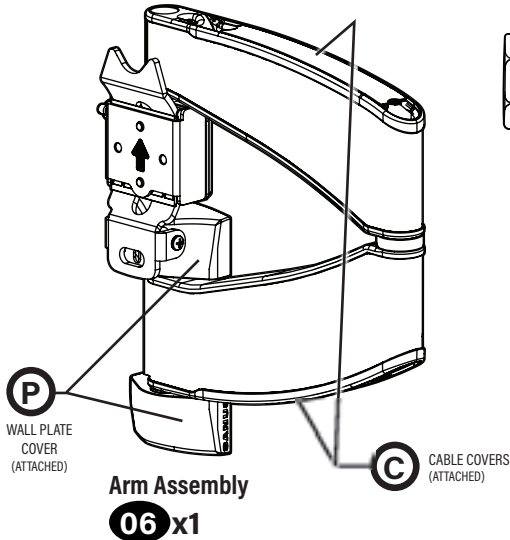

For concrete installations ONLY

CAUTION: Do not use in drywall or wood
Concrete Anchor

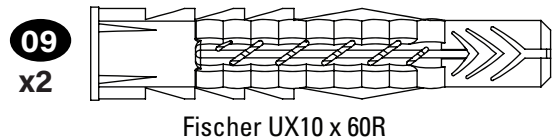

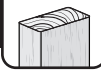

CAUTION: Avoid potential personal injury or property damage!

- Drywall covering the wall must not exceed 5/8 in. (1.5 cm)
- Minimum wood stud size: nominal 2 x 4 in. (5.1 x 10.2 cm) actual 1 1/2 x 3 1/2 in. (3.8 x 8.9 cm)
- Stud center must be verified

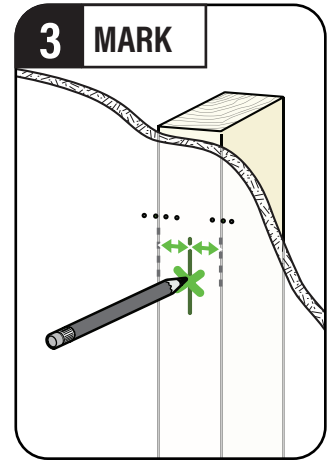
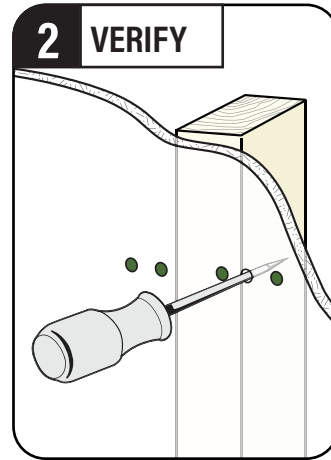
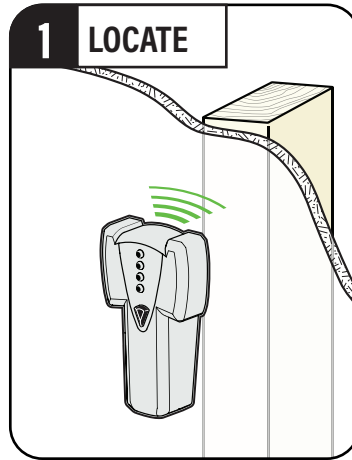
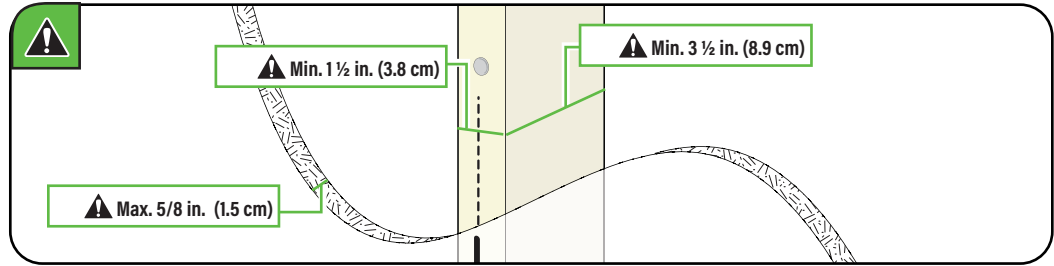

4 POSITION TEMPLATE

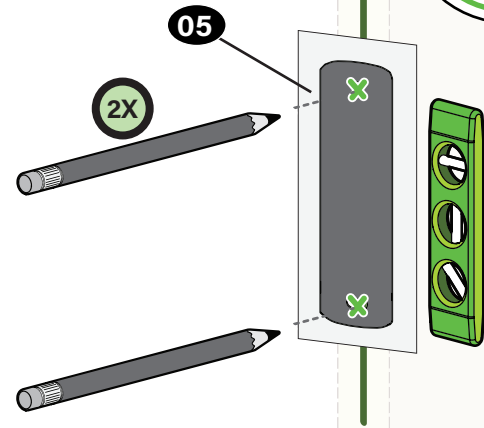

Visit
HeightFinder™
sanus.com/1172



TIP:

To calculate your precise wall plate location, check out our HeightFinder at sanus.com/1172.

5 DRILL

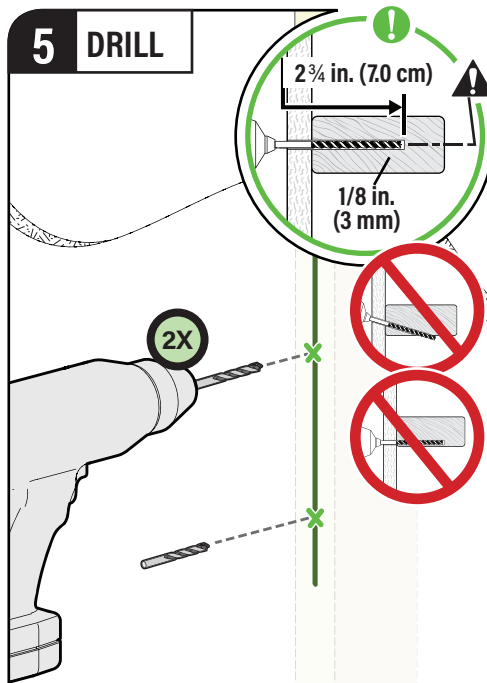

CAUTION:

Be sure you drill into the CENTER of the stud.

6 REMOVE COVERS

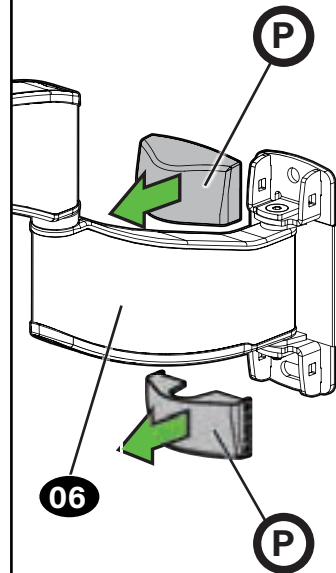

STEP 2A (continued)

7 SECURELY TIGHTEN

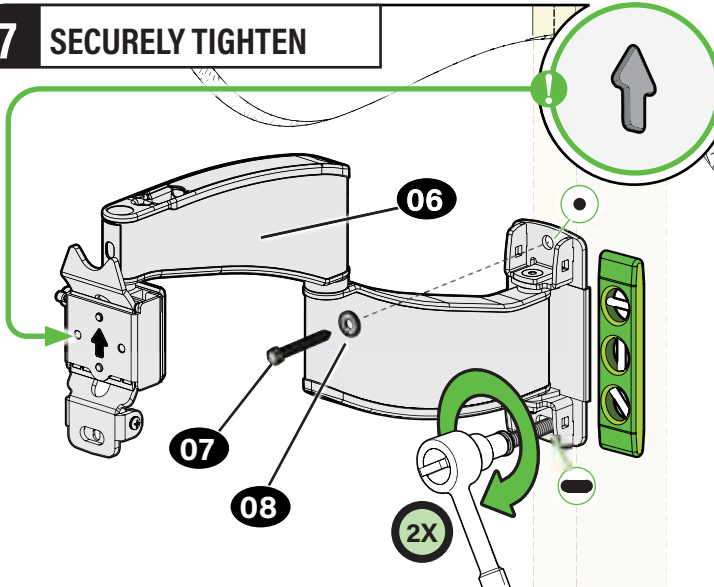

⚠ CAUTION: Avoid potential personal injury or property damage!

Both lag bolts **08** MUST BE firmly tightened to prevent unwanted movement of arm assembly **06**. Ensure the wall plate is securely fastened to the wall before continuing on to the next step.

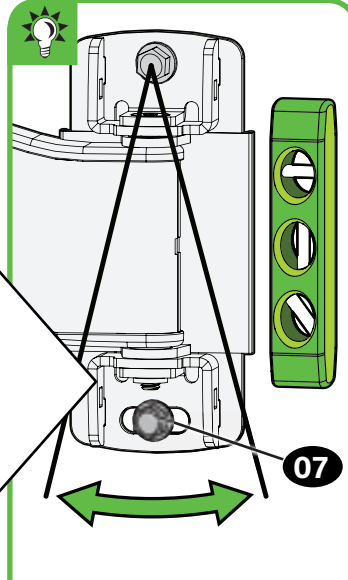

💡 TIP: You can make small level adjustments by loosening the bottom lag bolt **07** and shifting the wall plate until level.

8 INSERT COVERS

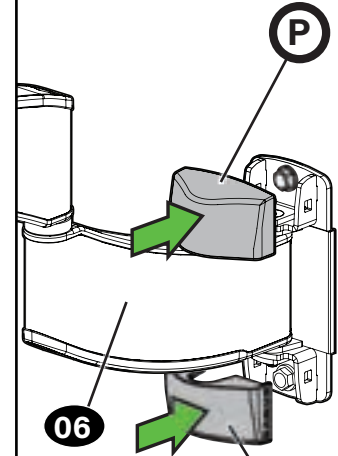

Go to STEP 3 on PAGE 16.

STEP 2B Attach Wall Plate



Solid Concrete or Concrete Block Installation

CAUTION: Avoid potential personal injury or property damage!

- Mount the arm assembly **06** directly onto the concrete surface (no surface covering)
- Minimum **solid concrete** thickness: 8 in. (20.3 cm)
- Minimum **concrete block** size: 8 x 8 x 16 in. (20.3 x 20.3 x 40.6 cm)

1 POSITION TEMPLATE

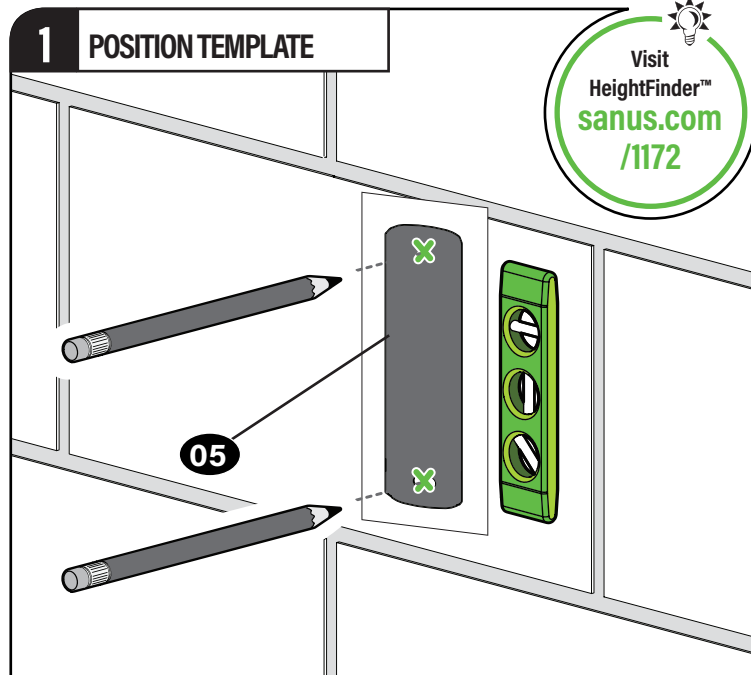

TIP:

To calculate your precise wall plate location, check out our HeightFinder at [sanus.com \[www.sanus.com/1172\]](http://www.sanus.com/1172).

STEP 2B (continued)

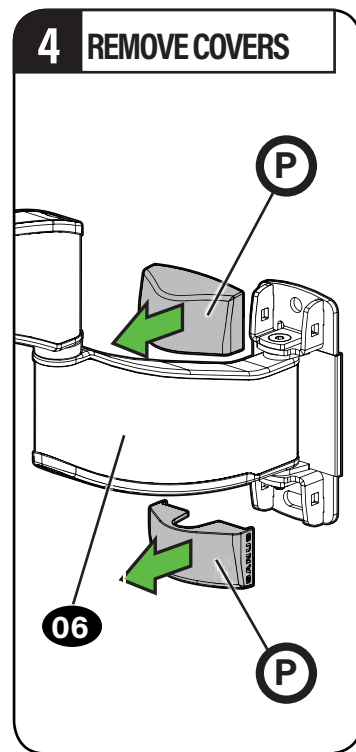
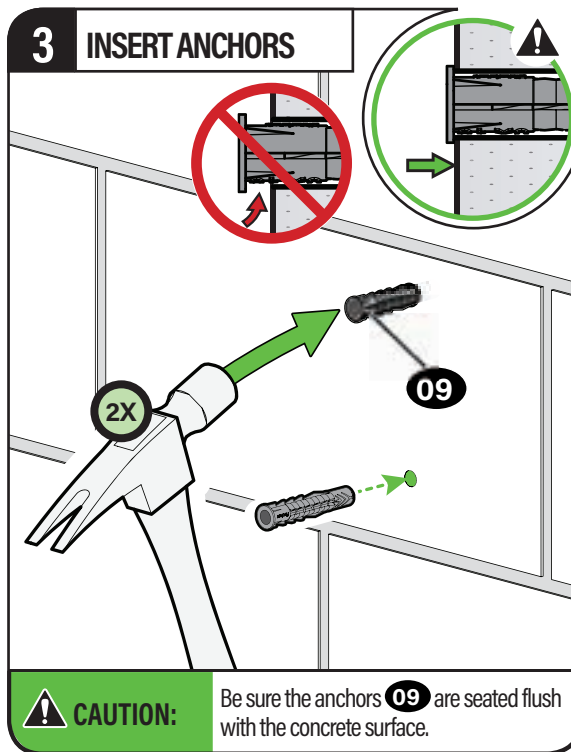
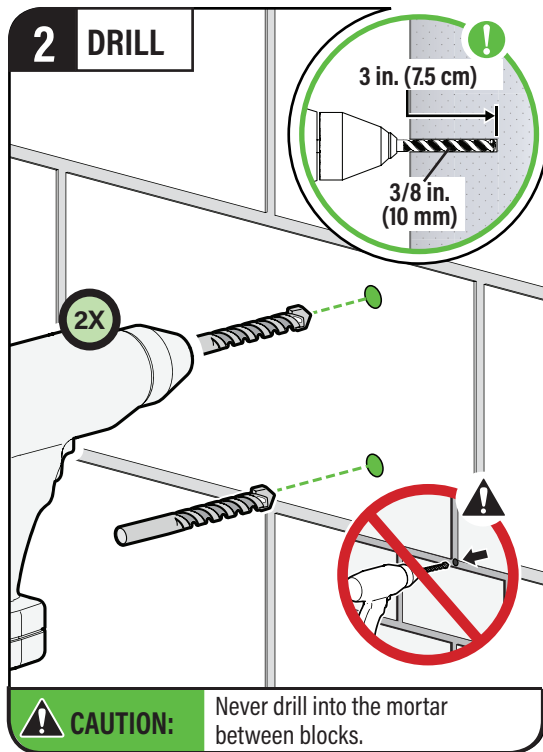

5 SECURELY TIGHTEN

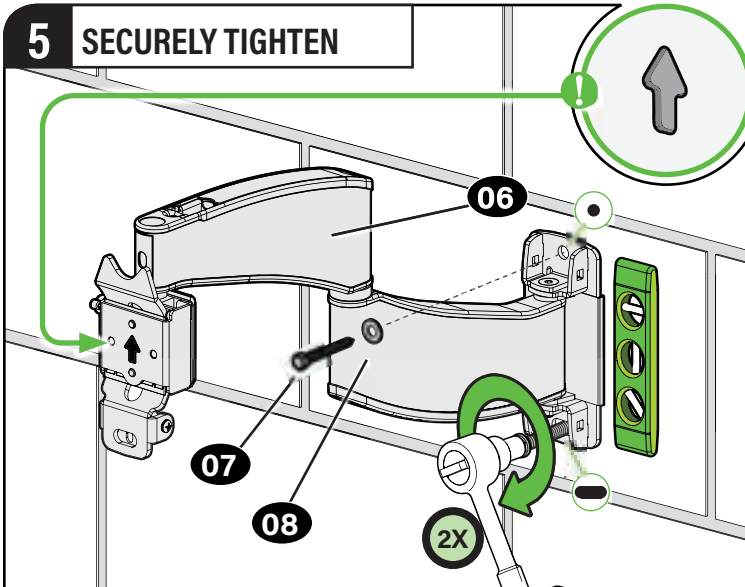

⚠ CAUTION: Avoid potential personal injury or property damage!

Both lag bolts **07** **MUST BE** firmly tightened to prevent unwanted movement of arm assembly **06**. Ensure the wall plate is securely fastened to the wall before continuing on to the next step.

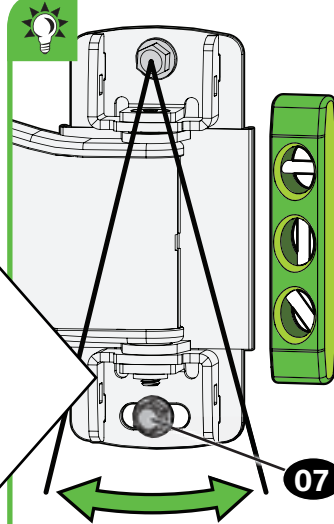

💡 TIP: You can make small level adjustments by loosening the bottom lag bolt **07** and shifting the wall plate until level.

6 INSERT COVERS

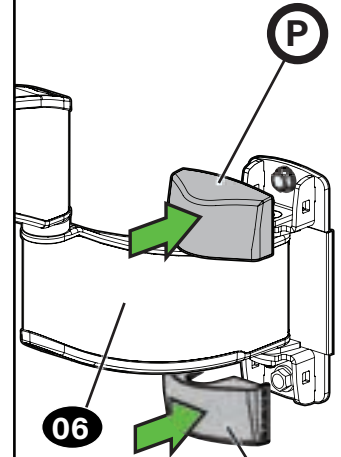

STEP 3

Attach TV to Wall Plate

WARNING: Before starting assembly, verify this part is undamaged. If damaged, do not return the damaged item to your dealer; contact Customer Service. Never use damaged parts!

Parts and Hardware for STEP 3

Securement
Screw

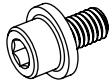

10-32 x 1/4 in.

10
x1

Hex Key

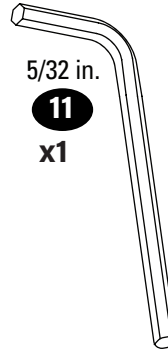

5/32 in.

11
x1

1 HANG YOUR TV



HEAVY! You may need assistance with this step.

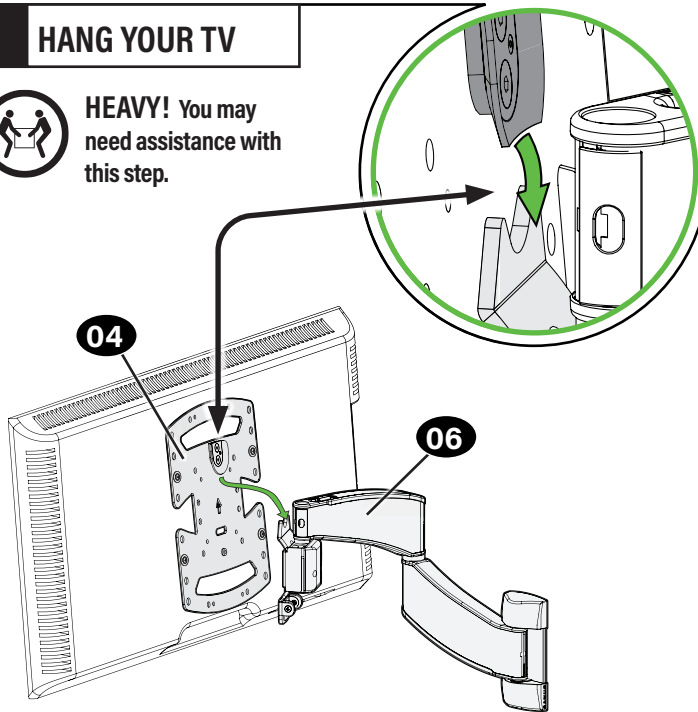

2 SECURELY TIGHTEN

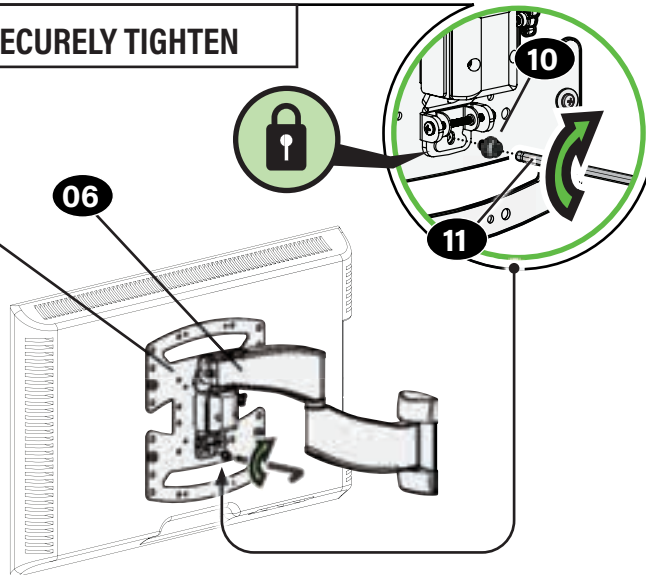

⚠ CAUTION: Avoid potential personal injury or property damage!

Always make sure your securement screw **10** is tightened, so the TV is securely fastened to the arm assembly **06**.

Manage Cables

1 ROUTE CABLES

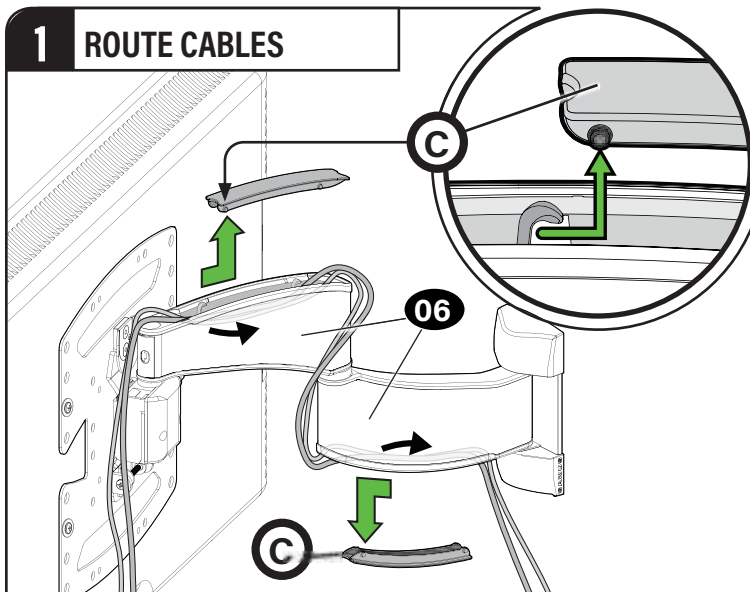

! IMPORTANT:

Pull arm **06** to its full extension, to leave enough slack and prevent stretching the cables when the arms are moved.

2 ATTACH COVERS

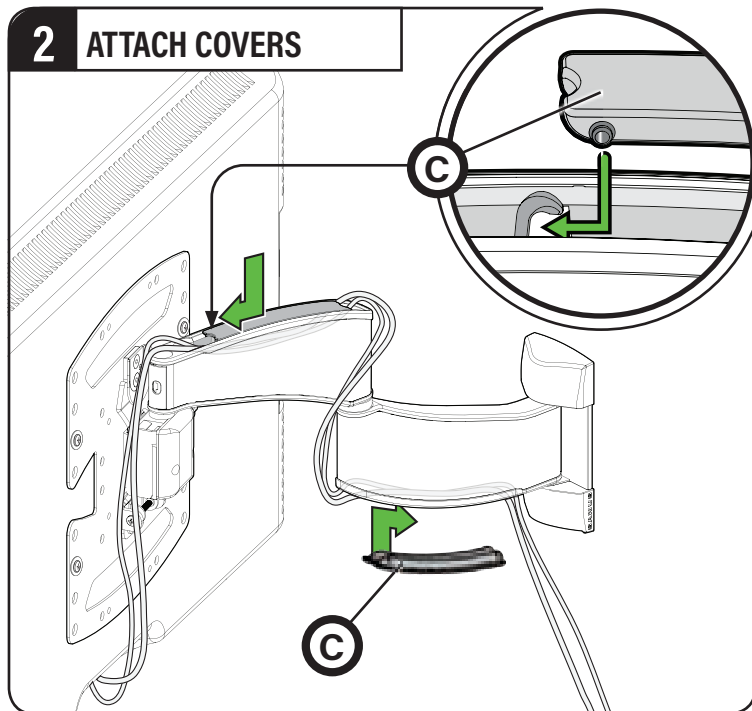

Adjustments



LEVEL ADJUSTMENT

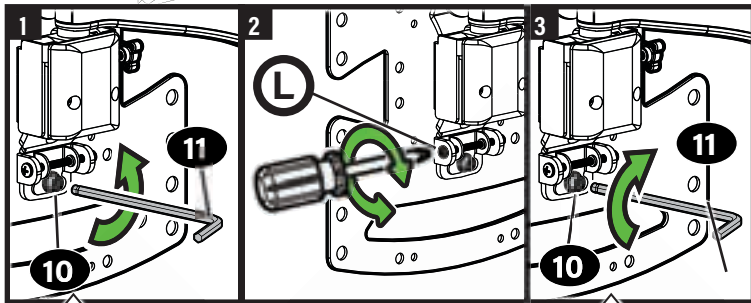
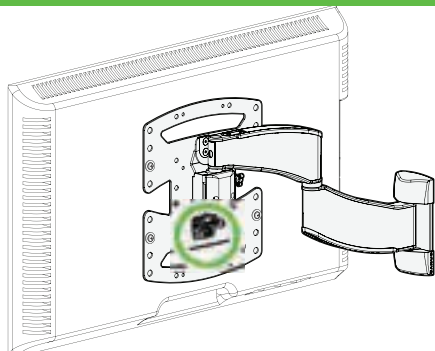

⚠ CAUTION:

Screw **10** MUST be loosened before turning screw **L**.

⚠ CAUTION:

Avoid potential personal injury or property damage!
Always make sure your securement screw **10** is tightened, so the TV is securely fastened to the arm assembly **11**.



TILT ADJUSTMENT

Your TV should adjust easily when moved, then stay in place.

Adjust the tilt tension knobs **T** if your TV naturally tilts up or down.

NOTE: If you do not intend to adjust the tilt for different viewing locations, you can tighten the tilt tension knobs **T** to prevent unwanted movement. If needed, use hex key to tighten more firmly.

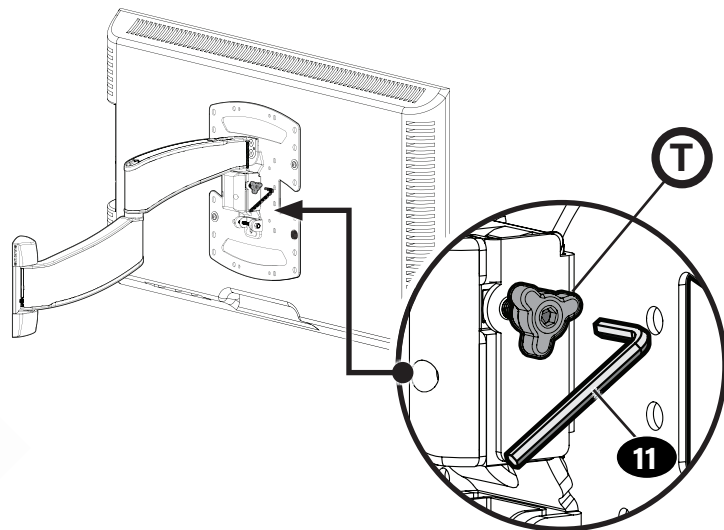



REMOVE THE TV



HEAVY! You may need assistance with this step.

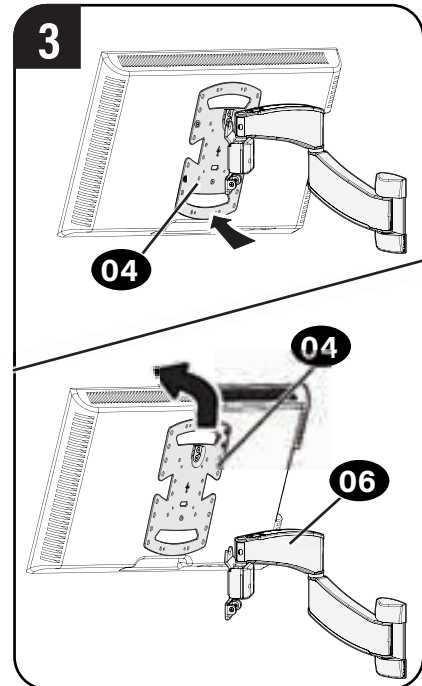
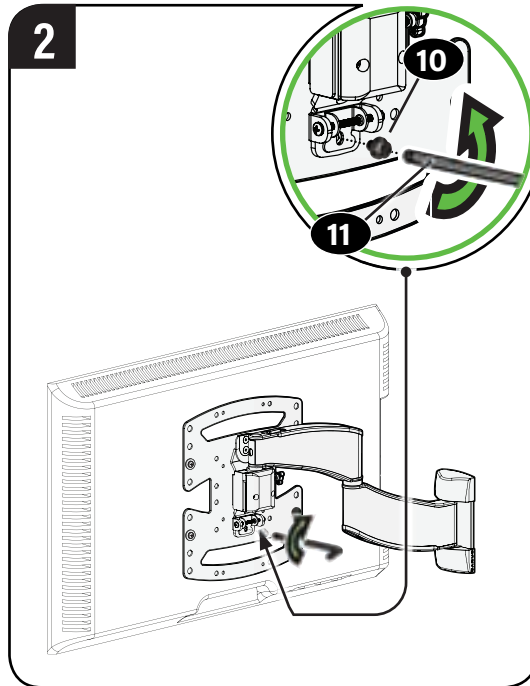
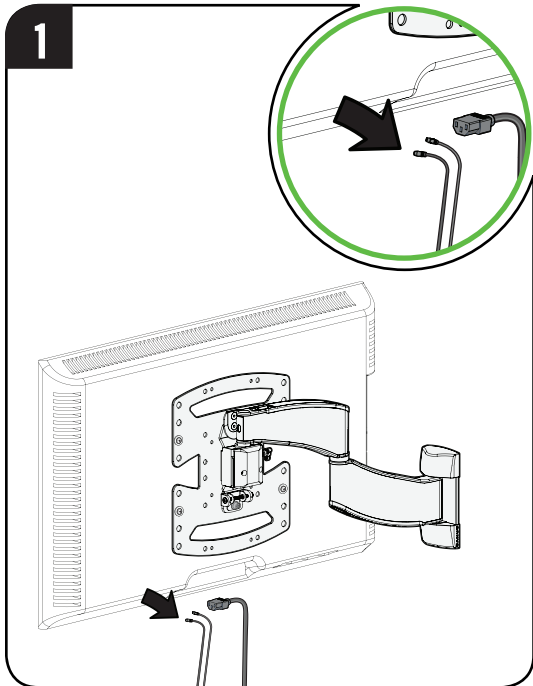



TV SUPPLIED SPACERS

A Use your TV supplied spacer for:

- **Flat Back TV** [TV brackets lay flat on your TV]

NOTE: M8 screws can be used without the washer for extra thread engagement.

FLAT BACK

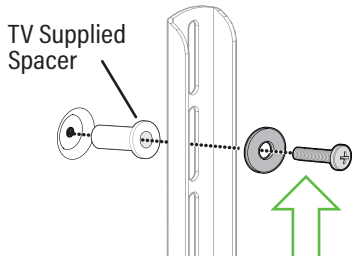
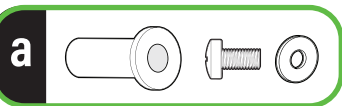
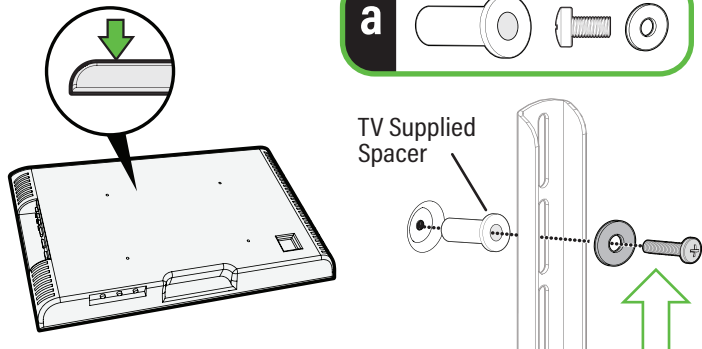

CAUTION: Avoid potential injury or property damage!
Use the correct screw length for adequate thread engagement.

- Too short will not hold the TV.
- Too long will damage the TV.

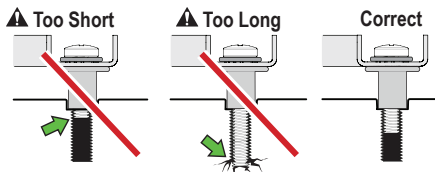

If you are uncertain about your hardware selection,
contact Customer Service

B Use your TV supplied spacer and spacer **03** for:

- **Flat Back TV with Extra Space Needed**
[for deep inset holes or cable interference]
- **Rounded or Irregular Back TV**
[TV brackets NOT resting flat on your TV]

NOTE: M8 screws can be used without the washer for extra thread engagement.

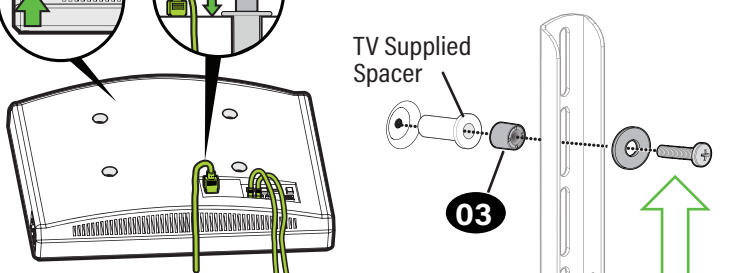
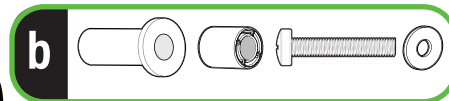
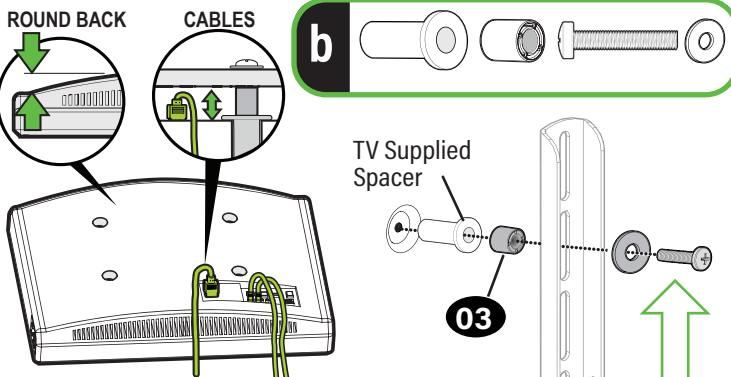

CAUTION: Avoid potential injury or property damage!
Use the correct screw length for adequate thread engagement.

- Too short will not hold the TV.
- Too long will damage the TV.

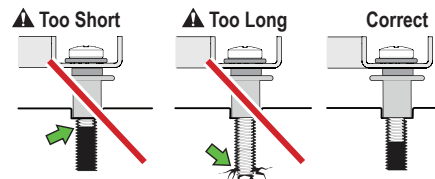

TV INTERFACE

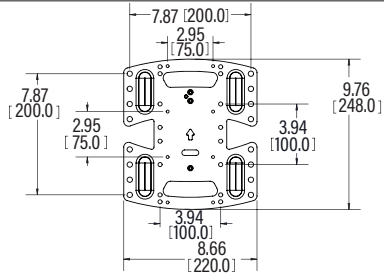

3-D

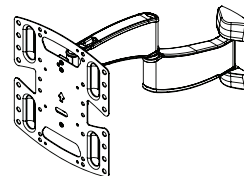

WALL PLATE

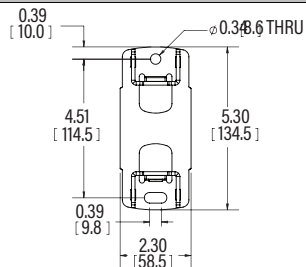

TOP VIEW - EXTENDED

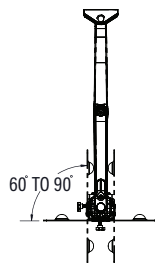

SIDE VIEW - EXTENDED

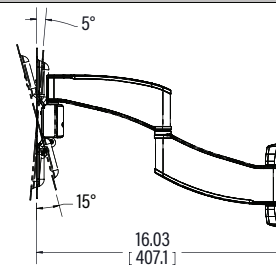

FULLY ASSEMBLED MOUNT

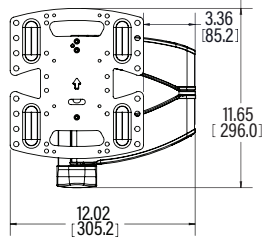

TOP VIEW - RETRACTED



SIDE VIEW RETRACTED

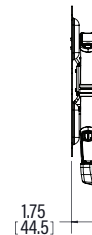

Antes de empezar, asegúrese de que este es el soporte adecuado para usted.

1 ¿Su televisor pesa (accesorios incluidos) **MÁS de 15.8 kg (35 lbs)?**



No – ¡Perfecto!

Sí – Este soporte NO es compatible. Visite MountFinder.Sanus.com o llame al : +1 (800) 359-5520 para encontrar un soporte compatible.

2 ¿De qué está hecha la pared?

⚠ PRECAUCIÓN:
NO instalar en paredes de yeso solo

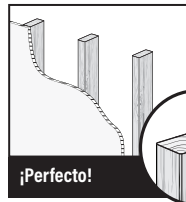

¿Paneles de yeso con montantes de madera?

¡Perfecto!



¿Hormigón macizo o bloques de hormigón?

¡Perfecto!



¿No está seguro?

Llame al servicio de atención al cliente:
+1 (800) 359-5520

3 ¿Tiene todas las herramientas necesarias?



Cinta métrica



Lápiz



Nivel

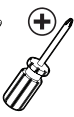

Destornillador



Taladro eléctrico



11 mm (7/16 pulg.)
Llave de tubo

Instalación sobre montante de madera



Localizador de montantes



Punzón

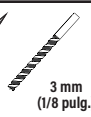

3 mm (1/8 pulg.)
Broca para madera

Instalación sobre hormigón



10 mm (3/8 pulg.)
Broca para hormigón



Martillo

4 ¿Preparado para empezar?

Lea atentamente estas instrucciones para asegurarse de que está familiarizado con el sencillo proceso de instalación. Consulte igualmente el manual de su televisor para conocer si existen requisitos especiales para el montaje de su aparato.

Si no entiende las instrucciones o si tiene dudas acerca de la seguridad de la instalación, el montaje o el uso del producto, póngase en contacto con el servicio de atención al cliente o llame a nuestro servicio técnico.

⚠ PRECAUCIÓN: Evite posibles lesiones personales y daños materiales.

- Este producto se ha diseñado para usarse en montantes de madera, hormigón macizo y paredes de bloques de hormigón: NO lo instale en paredes únicamente de yeso
- La pared debe ser capaz de soportar hasta cinco veces el peso combinado del televisor y el soporte
- No utilice este producto para ningún otro propósito que no sea el especificado explícitamente por el fabricante
- El fabricante no se responsabiliza de ningún daño o lesión resultante del montaje incorrecto o el uso indebido del producto

ESTAMOS A SU DISPOSICIÓN PARA AYUDARLE

¿Desea ver un vídeo que muestra lo fácil que será este proyecto de bricolaje? Puede verlo en: SANUS.com/3077

Acierte a la primera. HeightFinder™ indica el lugar donde debe taladrar. Descúbralo en: SANUS.com/1172

Nuestros expertos instaladores en EE. UU. están a su disposición para ayudarle. Llámenos al: **+1 (800) 359-5520**

Antes de comenzar

Retire el soporte de su televisor... ¡si ya estaba instalado, claro!

Instale cualquier accesorio que quiera añadir a su televisor.

Consulte todos los manuales de instalación de los accesorios para determinar si necesita **INSTALARLOS ANTES** de montar su televisor.

Proteja la pantalla de su televisor cuando lo tumbes para la instalación.

PASO 1

Cómo acoplar el soporte al televisor

PÁGINA 6

⚠ ADVERTENCIA: Este producto contiene piezas pequeñas que, en caso de ser tragadas, podrían causar asfixia. Antes de comenzar a montar la unidad, verifique que dispone de todas las piezas y que se encuentran en buen estado. Si no dispone de todas las piezas o alguna está dañada, no devuelva el elemento defectuoso al distribuidor. Póngase en contacto con el servicio de atención al cliente. Nunca utilice piezas en mal estado.

📄 NOTA: No se utilizarán todos los elementos de sujeción incluidos.

1.1 Seleccione el diámetro de los tornillos del televisor

Solo se adapta a su televisor un tamaño de tornillo.

1.2 Seleccione la longitud de los tornillos y los espaciadores del televisor

A SIN ESPACIADOR

• **Televisor con parte posterior plana** [los soportes del televisor se apoyan planos sobre su televisor]

Utilice tornillos de televisor **01**. No es necesario usar **03** espaciadores.

B ESPACIADOR NECESARIO

• **Televisor con parte posterior plana** que necesita espacio extra [para agujeros profundos o interferencia de cables]

• **Televisor con parte posterior redondeada o irregular** [los soportes de televisor NO se apoyan completamente planos en su televisor]

Use tornillos de televisor **01** largos y espaciadores **03** para crear espacio extra entre el televisor y el soporte del televisor.

1.3 Monte el soporte del televisor

1 LOCALIZAR

Centre el soporte del televisor **04** sobre la plantilla de orificios de su televisor tal y como se muestra.

Se incluyen orificios en varias posiciones para plantillas no centradas.

2 APRETAR FIRMEAMENTE

PASO 2

Cómo fijar la placa a la pared

PÁGINA 9

⚠ ADVERTENCIA: Este producto contiene piezas pequeñas que, en caso de ser tragadas, podrían causar asfixia. Antes de comenzar a montar la unidad, verifique que dispone de todas las piezas y que se encuentran en buen estado. Si no dispone de todas las piezas o alguna está dañada, no devuelva el elemento defectuoso al distribuidor. Póngase en contacto con el servicio de atención al cliente. Nunca utilice piezas en mal estado.

📄 NOTA: No se utilizarán todos los elementos de sujeción incluidos.

PASO 2A

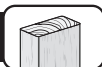

Colocación sobre montantes de madera

PÁGINA 10

⚠ PRECAUCIÓN: Evite posibles lesiones personales o daños materiales.

- Los paneles de yeso que cubren la pared no deben superar los 1,5 cm (5/8 pulg.)
- Tamaño mínimo de los montantes de madera: nominal 5,1 x 10,2 cm (2 x 4 pulg.), real 3,8 x 8,9 cm (1½ x 3½ pulg.).
- Debe comprobar el centro del montante

1 LOCALIZAR

2 VERIFICAR

3 MARCAR

4 COLOCAR LA PLANTILLA

5 TALADRAR

6 RETIRAR LAS CUBIERTAS **Ⓟ**

7 APRETAR FIRMEMENTE

💡 CONSEJO: Para calcular la ubicación precisa de su placa mural, descubra nuestro Height Finder en sanus.com [www.sanus.us/1172].

⚠ PRECAUCIÓN: Evite posibles lesiones personales o daños materiales. Los cuatro pernos tirafondo **07 DEBEN ESTAR** apretados con firmeza para evitar movimientos no deseados de la placa mural **06**.

8 INSERTAR LAS CUBIERTAS **Ⓟ**

Vaya al PASO 3 en la PÁGINA 16.

PASO 2B



Instalación en hormigón macizo o bloque de hormigón

PÁGINA 13

⚠ PRECAUCIÓN: Evite posibles lesiones personales o daños materiales.

- Monte la placa mural **06** directamente sobre la superficie de hormigón
- Grosor mínimo del **hormigón macizo**: 20,3 cm (8 pulg.)
- Tamaño mínimo del **bloque de hormigón**: 20,3 x 20,3 x 40,6 cm (8 x 8 x 16 pulg.)

1 COLOCAR LA PLANTILLA

💡 CONSEJO: Para calcular la ubicación precisa de su placa mural, descubra nuestro Height Finder en sanus.com [www.sanus.us/1172].

2 TALADRAR

⚠ PRECAUCIÓN: Nunca taladre sobre el cemento entre los bloques.

3 INSERTAR ANCLAJES

⚠ PRECAUCIÓN: Asegúrese de que los anclajes **09** estén asentados al mismo nivel que la superficie de hormigón.

4 RETIRAR LAS CUBIERTAS **Ⓟ**

5 APRETAR FIRMEMENTE

⚠ PRECAUCIÓN: Evite posibles lesiones personales o daños materiales. Los cuatro pernos tirafondo **07 DEBEN ESTAR** apretados con firmeza para evitar movimientos no deseados de la placa mural **06**.

6 INSERTAR LAS CUBIERTAS **Ⓟ**

PASO 3

Cómo fijar el televisor a la placa mural

PÁGINA 16

⚠ ADVERTENCIA: Antes de comenzar a montar la unidad, verifique que todas las piezas estén en buen estado. Si alguna está dañada, no devuelva el elemento defectuoso al distribuidor. Póngase en contacto con el servicio de atención al cliente. Nunca utilice piezas en mal estado.

1 COLGAR  **¡ELEMENTO PESADO!** Podría necesitar ayuda para realizar esta operación.

2 APRETAR FIRMEMENTE

⚠ PRECAUCIÓN: Evite posibles lesiones personales o daños materiales. Asegúrese siempre de que el tornillo de bloqueo **10** esté bien apretado, para que el televisor quede fijado de forma segura al conjunto del brazo **06**.

Gestión de los cables

PÁGINA 18

1 PASE LOS CABLES **⚠ IMPORTANTE:** xtienda el brazo **06** por completo antes de pasar los cables.

2 VUELVA A COLOCAR LA CUBIERTA

Ajustes

PÁGINA 19

NIVELACIÓN

⚠ PRECAUCIÓN: Se DEBE aflojar el tornillo **07** antes de girar el tornillo **L**.

⚠ PRECAUCIÓN: Evite posibles lesiones personales o daños materiales. Asegúrese siempre de que el tornillo de bloqueo **10** esté bien apretado, para que el televisor quede fijado de forma segura al conjunto del brazo **06**.

INCLINACIÓN

Su televisor debería ajustarse fácilmente al moverlo y luego mantenerse en su posición. Ajuste la perilla de tensión de inclinación **T** si su televisor se inclina por sí solo hacia arriba o hacia abajo.

📄 NOTA: Si no tiene intención de ajustar la inclinación para ver el televisor desde diferentes ángulos, puede apretar las perillas de tensión de inclinación a mano **T** para evitar movimientos indeseados. Si es necesario, utilice una llave hexagonal para apretar las perillas **T**.

EXTENSIÓN/RETRACCIÓN

RETIRADA DEL TELEVISOR  **¡ELEMENTO PESADO!** Podría necesitar ayuda para realizar esta operación.

 Resolución de problemas

PÁGINA 21

a: Use el espaciador suministrado con el televisor si este tiene la parte posterior plana (Y desea que quede más pegado a la pared).

b: Use el espaciador suministrado con el televisor y el espaciador **03** para: Televisores con dorsos redondeados (irregulares) o Cuando necesita espacio adicional para los cables.

Si no está seguro de su selección de piezas, póngase en contacto con el servicio de atención al cliente.

⚠ PRECAUCIÓN: Evite posibles lesiones personales y daños materiales. Use la longitud de tornillo adecuada para un enrosque seguro. Si es demasiado corto, no sujetará el televisor. Si es demasiado largo, dañará el aparato.

Dimensiones

PÁGINA 22

SANUS[®]

A brand of  Legrand

Thank you for choosing SANUS! Please take a moment to let us know how we did:

Legrand AV Inc.

6436 City West Parkway

Eden Prairie, MN 55344 USA

US: +1 (800) 359-5520

SANUS.com

©2022 Legrand AV Inc. All rights reserved. SANUS is a brand of Legrand. SANUS and the SANUS logo are registered trademarks.

All other brand names or marks are used for identification purposes and are trademarks of their respective owners.

Legrand AV Inc. • 6436 City West Parkway • Eden Prairie, MN 55344 USA

6901-603048 00